

Instructions for Use

Isolator Synergy™ EnCompass® Clamp and Guide System

OSH; OLH; GPM100

INDICATION FOR USE

The AtriCure Isolator Synergy EnCompass Clamp and Guide System is intended to ablate cardiac tissue during surgery.

CONTRAINDICATIONS

The AtriCure Isolator Synergy EnCompass Clamp and Guide System is not indicated for contraceptive coagulation of the fallopian tubes.

SYSTEM DESCRIPTION

The AtriCure Isolator Synergy EnCompass Clamp and Guide system is comprised of the following components:

1. Single-use EnCompass clamp (referred to hereafter as CLAMP) and a single-use accessory Glidepath™ Magnetic guide (referred to hereafter as GUIDE)
2. AtriCure Ablation and Sensing Unit (ASU) connected to an AtriCure Switch Box (ASB) (referred to hereafter as ASU/ASB) or Multifunctional Ablation Generator (MAG) [both referred to hereafter as “Generator” or “AtriCure RF Generator”]

The CLAMP is designed for use only with the ASU/ASB or MAG. When activated, the Generator delivers radiofrequency (RF) energy to the linear electrodes on the insulated jaws of the EnCompass clamp. The Operator controls the application of this RF energy by pressing the foot switch.

PRODUCT DESCRIPTION

The CLAMP is a single-use electrosurgical instrument offered in two configurations: standard length jaws (OSH), and long length jaws (OLH). All Isolator devices are configured as vascular clamps and feature clamping jaws of various lengths and curvatures. The AtriCure Isolator clamps feature an in-line handle with syringe-type actuation and button release mechanisms.

The GUIDE is a single-use surgical accessory designed to facilitate the guidance of surgical instruments through tissue during cardiothoracic surgical procedures. The GUIDE has magnetic attachment ends that connect to the metal tip of the CLAMP jaws inside of the jaw magnet cups.

Note: Please refer to the AtriCure ASU and ASB or MAG Instructions for Use for information specific to the Generator.

PACKAGE CONTENTS

- [1] One (1) CLAMP (OSH or OLH)
- [2] One (1) GUIDE (GPM100)

The CLAMP and GUIDE are supplied STERILE and NON-PYROGENIC in unopened, undamaged package.



WARNING

Do not re-sterilize or reuse the CLAMP and GUIDE as this could damage the device or result in infection.

NOMENCLATURE

This instruction refers to features of the CLAMP (Figure 1) and GUIDE (Figure 2) as follows:

CLAMP FEATURES

- [1] Moving Jaw
- [2] Fixed Jaw
- [3] Jaw Magnet Cups
- [4] Electrodes
- [5] Jaw Cover
- [6] Indicator Line
- [7] Handle
- [8] Closure Lever
- [9] Release Button
- [10] Connector
- [11] Connector Alignment Arrow

GUIDE FEATURES

- [12] Red Elastic
- [13] Magnetic ends

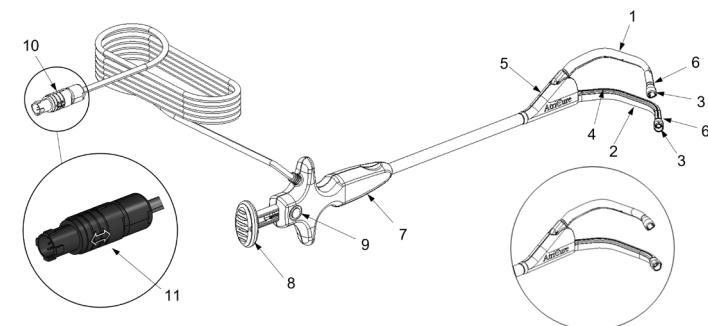
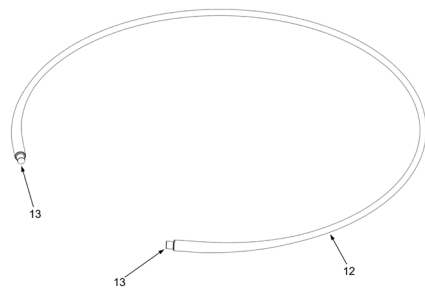

FIGURE 2 - GUIDE WITH FEATURE CALLOUTS



POTENTIAL COMPLICATIONS

FOR DEVICE

Possible complications related to the creation of the linear lesions in cardiac tissue using a clamp-type device may be included but not limited to:

- Tissue Cutting
- Perioperative heart rhythm disturbance (atrial and/or ventricular)
- Postoperative embolic complications
- Pericardial effusion or tamponade
- Damage to adjacent nerve and/or blood vessels
- Valve leaflet damage
- Conduction disturbances (SA/AV node)
- Acute ischemic myocardial event
- Injury to unintended surrounding tissue structures, including tears and punctures
- Bleeding requiring intervention to repair
- Extension of cardiopulmonary bypass

FOR PROCEDURE

Serious adverse events that may be associated with surgical ablation procedures on the heart (stand alone or concomitant to other cardiac surgery), include:

- Death,
- Excessive bleeding related to the procedure (defined as bleeding which requires >3 units of blood products and/or surgical intervention),
- Cardiac tamponade (if either open or catheter drainage is required),
- Pulmonary vein stenosis,
- Restrictive (constrictive) pericarditis,
- Endocarditis,
- Myocardial infarction (MI) per ACC guidelines,
- Stroke (resulting in permanent neurological deficit),
- Transient Ischemic Attack (TIA),
- Thromboembolism,
- Diaphragmatic paralysis,
- Esophageal-LA fistula or esophageal rupture,
- Atrial perforation or rupture,
- Ventricular perforation or rupture,
- Atelectasis,
- Pneumonia,
- Congestive Heart Failure,
- Cardiac Valve Injury,
- Persistent Pneumothorax (requiring intervention),
- Excessive Pain and Discomfort,
- Deep Sternal Wound Infection,
- Ventricular Arrhythmia (V. Tachycardia or V. Fibrillation)
- New Sinus Node Dysfunction, and
- Drug Reaction



WARNING
Read all instructions carefully prior to using the device. Failure to properly follow instructions may lead to injury and/or improper device function.

The use of the CLAMP and/or GUIDE should be limited to properly trained and qualified medical personnel. The use of the CLAMP and/or GUIDE from non-trained or unqualified medical personnel could potentially result in death or serious injury.

Due to the length of the jaws, the CLAMP should only be used with open surgical access where the CLAMP and adjacent structures can be easily visualized, to prevent collateral injury. Refer to Potential Complications list.

Use of the CLAMP and GUIDE on patients who have undergone previous cardiac surgeries may increase risk of damage during dissection and routing due to presence of adhesions in the tissue plans.

DEVICE USE INSTRUCTIONS

SETTING UP THE SYSTEM

CAUTION: The CLAMP is only compatible with an AtriCure Generator. Do not use the CLAMP with any other system, to prevent injury and/or equipment damage.

CAUTION: Monitoring systems that incorporate high frequency RF filtering devices are recommended for use with the Generator and CLAMP.

1. Install and power on the Generator and required accessories. The instructions for installing and operating the Generator, as well as a technical description of the system, are detailed in the Generator’s User’s Manual. Ensure the switch on the ASB is set to the black ISOLATOR DUAL receptacle on the front of the ASB (Figure 3).

FIGURE 3 - ASB WITH SWITCH SET TO ISOLATOR DUAL RECEPTACLE. CONNECTOR ALIGNMENT ARROW IN 12 O’CLOCK POSITION.

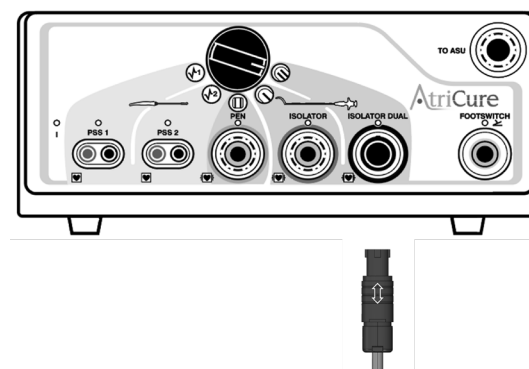

WARNING
Inspect the product packaging prior to opening to ensure the sterility barrier is not breached. If the sterility barrier is breached, do not use the CLAMP or GUIDE to avoid the risk of patient infection.

CAUTION: Do not drop the CLAMP as this may damage the device. If the CLAMP is dropped, do not use. Replace with a new CLAMP.

2. Inspect the product packaging prior to opening to ensure the sterility barrier is not breached. Ensure sterile expiration date has not been exceeded. Remove the CLAMP and GUIDE from the package per standard sterile technique. Do not use if CLAMP or GUIDE is dropped.

CAUTION: Do not connect the CLAMP to the Generator if the Connector pins are bent.

3. Inspect the Cable and Connector pins and do not use the CLAMP if the Cable is frayed or if the insulation is damaged or if the Connector pins are bent. With the Connector Alignment Arrow symbol in the 12 o’clock position, push the Connector into the black ISOLATOR DUAL receptacle on the front of the ASB (Figure 3) or Clamp receptacle on the front of the MAG (refer to MAG Instructions for Use for MAG interface). Avoid twisting the Connector during insertion into the ISOLATOR DUAL receptacle, which could cause bent pins in the Connector.
4. If the CLAMP is to be used with the supplied GUIDE, go to section “Routing the GUIDE”. If the CLAMP is not to be used with the GUIDE, go to section “Positioning the CLAMP”.

ROUTING THE GUIDE

i The GUIDE may be used with commercially available general dissection or surgical clamping tools (auxiliary tools) to create and maintain a dissection plane that facilitates placement of the CLAMP around tissue structures per standard surgical technique. The magnetic GUIDE ends will attract to ferrous metal instruments and devices.



WARNING
Dissection of epicardial fat where the CLAMP may interact with the Epicardium during placement may increase the potential for tissue damage.

5. Ensure adequate dissection is performed to facilitate GUIDE and CLAMP routing and placement. Avoid dissection of epicardial fatty areas prior to placement of the CLAMP. Epicardial fat may be dissected after placement to support lesion creation.



WARNING
Do not use the CLAMP if there is any sign of damage as it may adversely affect ablation performance.

6. Inspect the GUIDE for any cracks or defects prior to routing. Do not use and replace with another GUIDE if any cracks or defects are present.



WARNING
If using auxiliary tools to retrieve the GUIDE, use caution to avoid tissue perforation.

7. Introduce Ends of the GUIDE into the desired dissection planes. Use blunt auxiliary tools or fingers to route and retrieve the GUIDE Ends with visualization.
8. If desired, connect the magnetic GUIDE Ends together and rotate connected GUIDE Ends around tissue structures to provide alternative access for the CLAMP (Figure 4).

FIGURE 4 - MAGNETIC GUIDE ENDS CONNECTED TOGETHER

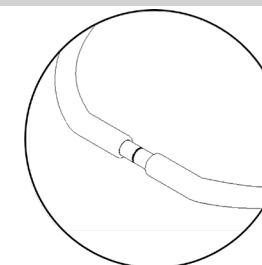

9. Verify intended position of the GUIDE around tissue structures by feel and/or visualization.

CONNECTING THE GUIDE TO THE CLAMP

i The GUIDE Ends are non-specific and can connect to either CLAMP jaw.

10. Inspect the CLAMP prior to routing. Do not use if any defects are present.
11. Connect the GUIDE to the CLAMP by inserting each GUIDE End into the Magnet cup on each CLAMP Jaw. The GUIDE End will attract to the metal tip of each CLAMP Jaw. Ensure the GUIDE is magnetically attached to the CLAMP prior to routing. Ensure the Red Elastic portion of the GUIDE is not crossed by feel and/or visualization (Figure 5).

FIGURE 5 – GUIDE ATTACHED TO CLAMP

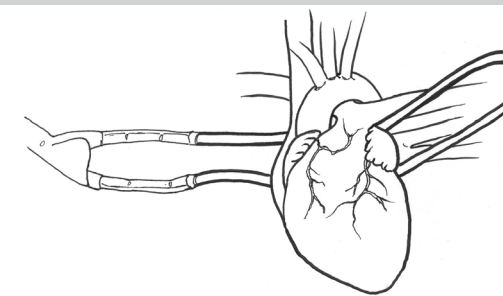

12. Grab the Red Elastic portion of the GUIDE that is routed around the desired tissue structures.

POSITIONING THE CLAMP



WARNING
Use of the CLAMP and GUIDE while off cardiopulmonary bypass could cause increased risk of tissue perforation and/or circulatory interruption.

i If cardiopulmonary bypass is to be initiated, it is recommended to do so before positioning the CLAMP.



WARNING
Failure to pull the TEE probe back away from the CLAMP site prior to routing may cause damage to surrounding structures.

13. Pull the TEE probe back away from the CLAMP site prior to routing CLAMP or GUIDE



WARNING
When placing the CLAMP, caution should be taken to pull the CLAMP into position with the GUIDE when possible. Pushing the CLAMP into position may cause damage to surrounding structures.

14. Place clamp within the sternotomy. If additional space is needed, partially close the jaws and/or loosen pericardial stay sutures. Position the CLAMP while keeping the Jaw Cover away from cannulas, catheters, sutures and non-target tissue structures.
15. Ensure CLAMP tips are aligned with the target tissue plane.
16. Once CLAMP tips are properly aligned to access target tissue, pull the GUIDE while allowing the CLAMP Jaws to passively follow into position. If resistance to passing the CLAMP is encountered, do not push the CLAMP; inspect to ensure tips are aligned to tissue planes and consider additional dissection and/or passing from an alternate approach.
17. Ensure that both sides of the GUIDE remain in tension throughout CLAMP positioning and monitor for GUIDE kinking/bending near the GUIDE ends. If kinking/bending is noticed, pull the GUIDE taut prior to continuing to route the CLAMP and GUIDE.



WARNING
Unnecessary removal of the GUIDE while the CLAMP is in position may cause damage to the surrounding structures. There is no need to remove the GUIDE at this step as the GUIDE does not interfere with clamping or ablation.

18. Once the CLAMP is in position, keep the GUIDE attached.

CAUTION: Do not insert excessive tissue into the Jaw Cover as it may result in poor ablation at the Jaw Cover.

CAUTION: Do not ablate tissue greater than 15 mm thick with the CLAMP. Tissues greater than 15 mm thick may not be fully ablated.

19. Center the target tissue along the middle of the Fixed and Moving CLAMP Jaws.



WARNING
Any tissue within the RF energy field may experience heating and/or tissue damage. Ensure non-target tissue is adequately

should be properly labeled with an RGA number and an indication of the biohazardous nature of the contents of shipment. Instructions for cleaning and materials, including appropriate shipping containers, proper labeling, and an RGA number may be obtained from AtriCure, Inc.

DISCLAIMER STATEMENTS

Users assume responsibility for approving the acceptable condition of this product before it is used, and for ensuring that the product is only used in the manner described in these instructions for use, including, but not limited to, ensuring that the product is not re-used.

Under no circumstances will AtriCure, Inc. be responsible for any incidental, special or consequential loss, damage, or expense, which is the result of the deliberate misuse or re-use of this product, including any loss, damage, or expense which is related to personal injury or damage to property.

separated from the RF field. Ensure non-target tissue is protected from the RF field by carefully placing and orienting the Electrodes. Refer to the Potential Complications List.
Do not ablate with the Closure Lever unlatched. Ablating with the Closure Lever unlatched could result in tissue perforation.

20. Squeeze the Closure Lever until it latches to close the CLAMP Jaws. Ensure only target tissue is clamped within the Jaws by feel and visualization. Ensure that no target tissue extends beyond the Indicator Line on either the Fixed or Moving Jaw or into the Jaw Cover.

ABLATION OF TARGET TISSUE



WARNING

Electrosurgery should be used with caution in the presence of internal or external pacemakers and/or internal cardiac defibrillators (ICD). Interference produced with the use of electrosurgical devices can cause devices such as a pacemaker and/or ICD to enter an asynchronous mode, block pacemaker conduction, or deliver inappropriate shock therapy. Consult the pacemaker manufacturer or hospital Cardiology department for further information when use of electrosurgical appliances is planned in patients with cardiac pacemakers and/or ICD.

i The Generator measures tissue impedance throughout the ablation cycle and uses this information to control the application of energy to the tissue. The Generator determines the minimum energy delivery required to create a transmural (full thickness) lesion based on tissue impedance and delivers only that amount of energy to the tissue. The time necessary to create a transmural lesion depends on tissue thickness, composition, and the length of tissue captured between the electrodes.

i See the Generator Instructions for Use for complete list of Error Codes. Recoverable E errors will remain on the display until the footswitch is pressed again.

⚠ CAUTION: Do not ablate in a pool of blood or other fluids as this may extend the ablation time. Users should suction excess fluids away from the Jaws prior to ablation. Immersion of any part of the CLAMP in fluids may also damage the device.

21. Ensure the CLAMP Jaws are not submerged in fluid. Remove any fluid from the field prior to ablation.

⚠ CAUTION: : Do not touch the Electrodes of the CLAMP while activating the Generator Touching the CLAMP Electrodes during Generator activation could result in burn to the operator.

⚠ CAUTION: Do not touch the Electrodes of the CLAMP to metal staples or clips, or to sutures while activating the Generator.

⚠ CAUTION: When the Generator is activated in conjunction with the CLAMP, the conducted and radiated electrical fields may interfere with other electrical medical equipment. Refer to the Generator IFU for more information regarding potential electromagnetic or other interference, and advice regarding avoidance of such interference.

⚠ CAUTION: When the Generator and Handpiece are used on a patient simultaneously with physiological monitoring equipment, ensure that the monitoring electrodes are placed as far as possible from the surgical electrodes. Be sure to position the Handpiece cables so that they do not come in contact with the patient or the other leads.

⚠ CAUTION: Do not use this device in the presence of flammable anesthetics; other flammable gases; near flammable fluids such as skin prepping agents and tinctures; flammable objects; or with oxidizing agents. Observe appropriate fire precautions at all times.

22. Activate the Generator by depressing the foot switch or pressing the button. When the Generator is activated, the Generator will emit an audible tone indicating that energy is being delivered between the Jaws of the CLAMP. When the continuous tone switches to intermittent and the transmural light is flashing on the ASU, release the foot switch. For MAG, the tone will switch to intermittent and the graphed line will drop below the transmural line. Some ablations may take multiple activations with the foot switch to reach the intermittent tone and flashing transmural light.

23. Open the Jaws prior to removing the CLAMP. To open the Jaws, press the Release Button and slowly release the Closure Lever. Do not allow the Jaws to spring back. Be aware of any surrounding tissues that could be damaged as the Jaws open. If the Jaws do not open after pressing the Release Button, pull on the closure lever.

24. Inspect the surgical area to ensure adequate ablation.



WARNING

Do not use abrasive cleaners or electrosurgical tip cleaners to clean debris from the Jaws. Use of abrasive cleaners or electrosurgical tip cleaners can damage the electrodes and result in device failure. Use saline-soaked gauze to clean debris off the electrodes.

25. For optimal performance, keep the CLAMP electrodes clear of coagulum by wiping with a saline-soaked gauze after ablation.

26. Repeat ablation process as necessary.

REMOVING AND DISPOSING OF THE CLAMP AND GUIDE

27. After removing the CLAMP from the tissue structures, disconnect the GUIDE by gripping the GUIDE close to the CLAMP connection and pulling straight out of the CLAMP jaw Magnet Cups.

⚠ CAUTION: Do not attempt to use a CLAMP that has reached its time limit expiration. The CLAMP has an 8 hour useful life that is tracked by the Generator. The CLAMP will no longer function after 8 hours of use and the Generator will display a message indicating that the CLAMP must be replaced.

28. After use this CLAMP should be treated as medical waste and disposed of following hospital protocol.

29. Ensure the GUIDE is removed from the surgical field prior to the completion of the surgical procedure. After use this GUIDE should be treated as medical waste and disposed of following hospital protocol.

RETURN OF USED PRODUCT

If for any reason this product must be returned to AtriCure, Inc., a return goods authorization (RGA) number is required from AtriCure, Inc., prior to shipping. If the product has been in contact with blood or body fluids, it must be thoroughly cleaned and disinfected before packing. It should be shipped in either the original carton or an equivalent carton, to prevent damage during shipment; and it

EXPLANATION OF SYMBOLS ON PACKAGE LABELING

REFER TO THE OUTER PACKAGE LABEL TO SEE WHICH SYMBOLS APPLY TO THIS PRODUCT.

	Caution	Rx ONLY	Caution: Federal Law (US) restricts this device to sale by or on the order of a physician		Do Not Re-Sterilize
	Non-Pyrogenic		Waste Electrical and Electronic Equipment		Do Not Use if Package is Damaged
	Sterilized using Ethylene-Oxide		Serial Number		Manufacturer
	Do Not Re-Use		Not made with Natural Rubber Latex		Catalogue Number
	Expiration Date		Follow instructions for use		Model
	Batch code		Informational note		Contain Phthalates
 Temperature Storage Limit			 Humidity Storage Limit		



AtriCure Inc.
7555 Innovation Way
Mason, Ohio 45040 USA
+1 866 349 2342
+1 513 755 4100